

AUTOMATIC FIRE EXTINGUISHER

Revan Kumar D, Karthik P
B.E 4th year Mechanical Engineering, R.M.K Engineering College

INTRODUCTION

The rapid depletion of existing fossil fuel sources and the environmental problems caused globally by the combustion products have made the whole world go crazy in search for alternative fuel to power the automobiles. The main aim is to reduce the usage of organic fuel powered vehicle and to design a vehicle which works perfectly in the growing fuel area i.e. electric powered vehicle. This will not only save the organic fuel but also to work upon the **NO POLLUTION** rides and future fuel. To begin it from the grass root a single passenger kart (named **ERUDITE**) powered by the **3 HP PMDC 48V** motor is designed and fabricated, where the source of running the motor is 48V battery. To make our cause more meaningful alternative material (**Aluminum 6063**) is used for the frame rather than the conventional mild steel. The frame is designed in order to encapsulate all the components of the kart, including a driver, ergonomically and subjected it to various real life scenarios by performing finite element analysis using solid works simulation. **Simple four bar mechanism** is used to steer the kart to the required turning radius. **Disc brake** has been installed in rear wheels for the effective braking along with the **handbrake** as a precaution measure in case of brake failures. **Sprocket and chain** mechanism is used to transmit the power to the rear wheels. Statistically most of the accidents that occur in electric vehicles is caused due to fire. **The major cause of fire in an electric kart is due to overload of motor especially during braking, short circuit in controller and battery.** Since the hot spot of a motor is the armature, it is the first component to catch fire and hence the armature temperature has to be monitored continuously so that fire can be prevented. According to neurologists, an average human brain takes 3 seconds to recognize the situation and another two seconds to react. **This time is enough for a fire to spread and cause severe damage to the driver as well as the kart. Hence, an automated mechanism was designed and installed in the kart to extinguish any fire immediately.**

(Let's first discuss in detail about Electric circuit of a kart and then evaluate the possible conditions for fire accidents.)

MOTOR:



Fig 1 Photograph of PMDC Motor

SPECIFICATIONS:

GETTYS.FANUC DC SERVO MOTOR	
STALL TORQUE 12 NM	VOLT 90V
MAX RPM 3000	PULSE AMPS 30A
TACHO 6 VOLTS/1000 RPM	

BATTERY SPECIFICATION

EXIDE – LEAD ACID BATTERY		
Voltage –12V	Current– 26A	4 No’s
Dimension - 6 x 6 inches		
4 batteries connected in series = 48V		

CONTROLLER CIRCUIT WITH MOTOR:

ERUDITE CONTROLLER AND DRIVER CIRCUIT

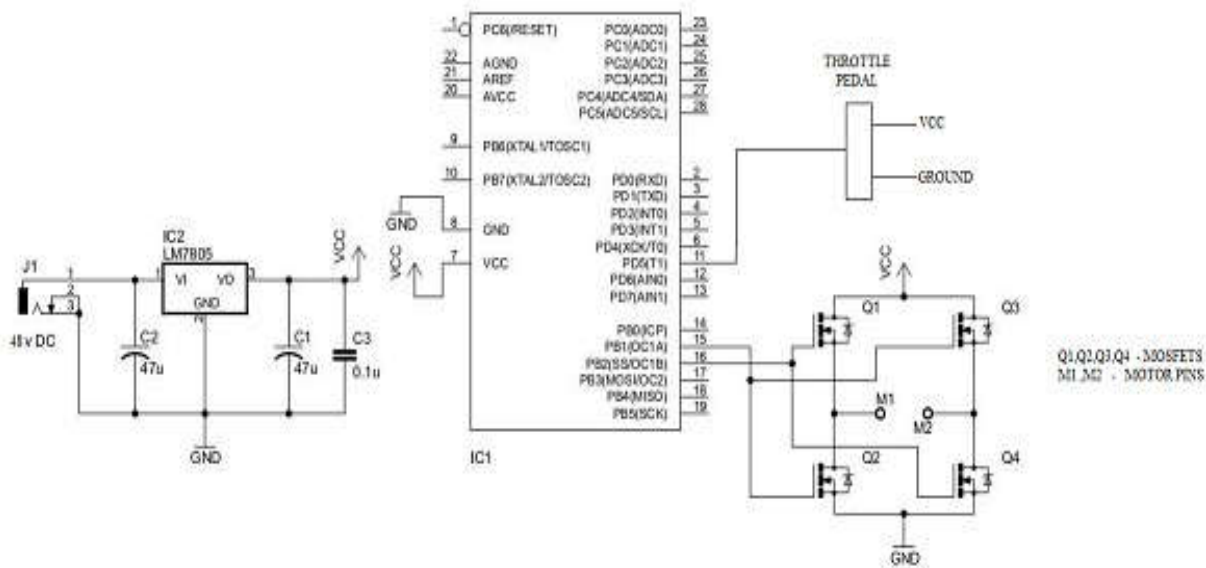

Fig 2 . Kart Controller and Driver Circuit Diagram

- The motor positive and negative terminals are given to M+ and M- pins of the controller respectively.
- The battery positive and negative terminals are given to B+ and B- pins of the controller respectively, through the
- Throttle is based on rheostat mechanism, i.e. More the amount of throttle pressed, resistance decreases, current increases, as a result speed of the motor increases.

- The controller consists of 16 pins, of which:
 - 11th pin: throttle
 - 15th pin and 16th pin: Driver circuit

KART CIRCUIT:

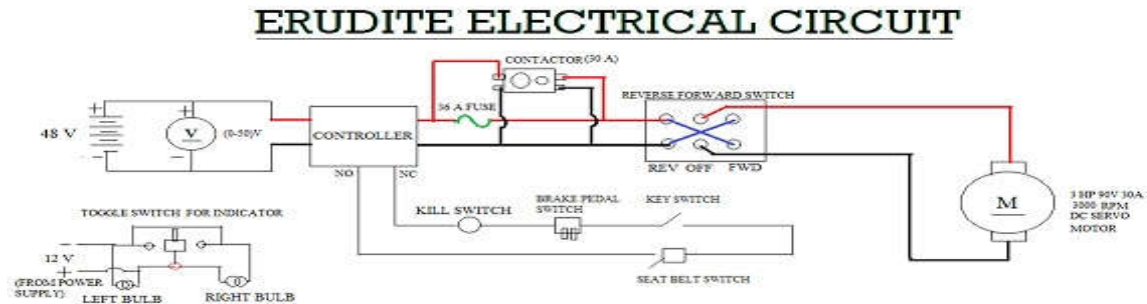

Fig 3 . Kart Electrical Circuit Diagram

- The battery used in the above circuit is 48 volt 26Ah.
- The circuit is provided with fuse of 36A, to break the circuit in case of emergency.
- The driver circuit consists of 10 MOSFETS.
- Capacitor is used for charging and discharging of current, i.e. it is used as back up for battery.
- The field H Bridge is used to protect the circuit components from the back emf produced by the motor.
- The current sense is directly given to the controller. It is used to measure the amount of current flowing through the motor.
- Manual switch is used to open and close the whole circuit.

INSTANCES OF FIRE OCCURRENCE - ANALYSIS

Overload of motor:

When an electric motor is running normally, it will be generating electricity as well. This generated electricity will oppose the power supply to the motor, and thus decrease the current being consumed by the motor. This is known as Back EMF (Electro Motive Force). If the motor is then overloaded it will slow down. This will decrease the amount of Back EMF being generated, and so the current will increase dramatically. This will cause overheating, depending on how much the motor is overloaded. If it is stalled, it may well catch fire.

Causes for overload:

Short circuit:

The short circuit of the controller and driver circuit causes severe damage to the motor. In case the battery terminals are short circuited it leads to fire accidents in the kart.

Braking:

Whenever the brake is applied to stop the vehicle, a large amount of on-load is applied on the motor shaft which is connected with rear axle through sprocket and chain. As a primary prevention measure we have included a brake sensor in the brake pedal which automatically cut off the power supply of the motor. But this measure is not a reliable one. So in order to find a reliable and permanent solution for fire accidents problems, an automatic fire extinguisher concept is devised and implemented successfully in the kart.

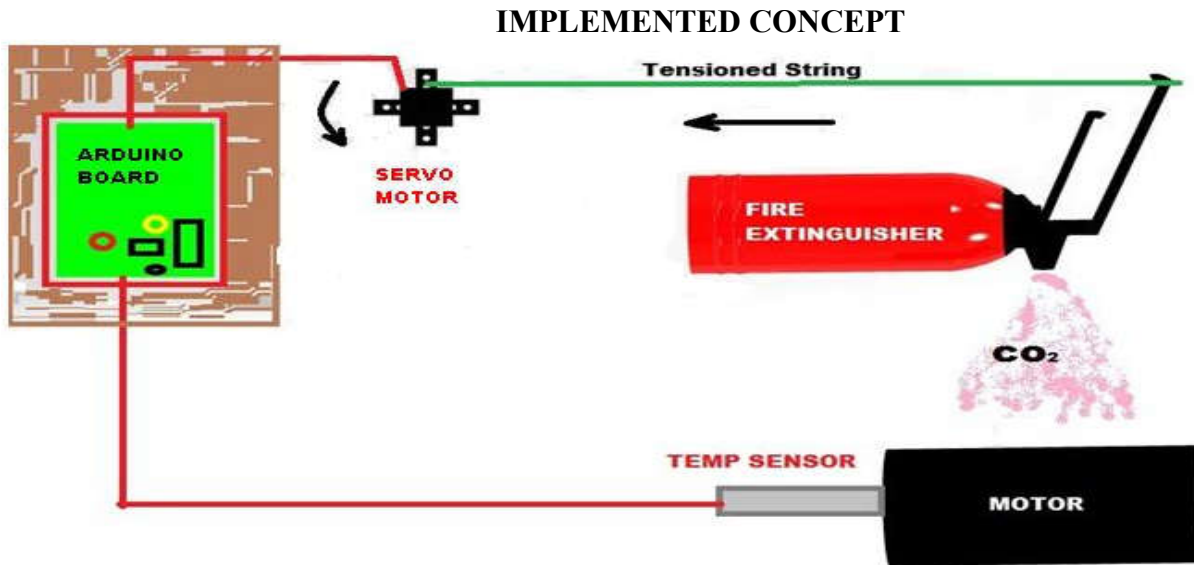

Fig 4. Flow

Diagram of Automatic Fire Extinguisher in our Kart

COMPONENTS REQUIRED:

- Temperature Sensor
- Servo Motor
- Atmega368p Controller
- Fire Extinguisher

TEMPERATURE SENSOR:

DS18B20 Programmable Resolution 1-Wire Digital Thermometer

PIN CONFIGURATIONS

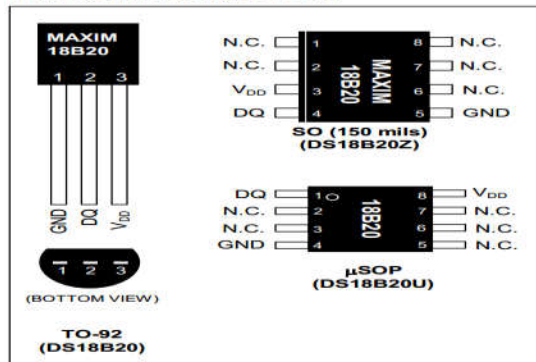

(Referred from internet)

Features:

- Unique 1-Wire® Interface Requires Only One Port Pin for Communication
- Each Device has a Unique 64-Bit Serial Code Stored in an On-Board ROM
- Multidrop Capability Simplifies Distributed Temperature-Sensing Applications
- Requires No External Components
- Can Be Powered from Data Line; Power Supply Range is 3.0V to 5.5V

- Measures Temperatures from -55°C to +125°C (-67°F to +257°F)
- $\pm 0.5^\circ\text{C}$ Accuracy from -10°C to +85°C
- Thermometer Resolution is User Selectable from 9 to 12 Bits
- ♣ Converts Temperature to 12-Bit Digital Word in 750ms (Max)

SERVO MOTOR

Weight (g)	51
Torque (kg)	9
Speed(Sec/60deg)	0.2
A(mm)	44
B(mm)	40
C(mm)	39
D(mm)	20
E(mm)	54
F(mm)	27

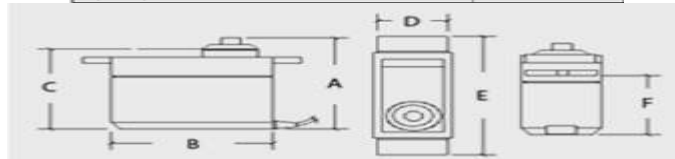

Spec.

Torque: **9kg @ 4.8v, 8kg @ 6v**

Weight: **51g**

Speed: **0.21 / 60deg @ 4.8v, 0.20 / 60 deg @ 6v**

Voltage: **4.8v~6v**

Plug: **JR style**

Features:

Metal Gears

Dual Ball-race

ARDUINO MICROCONTROLLER

Microcontroller	ATmega328
Operating Voltage	5V
Input Voltage (recommended)	7-12V
Input Voltage (limits)	6-20V
Digital I/O Pins	14 (6-PWM)
Analog Input Pins	6
DC Current per I/O Pin	40 mA
DC Current for 3.3V Pin	50 mA
Clock Speed	16 MHz
Length	68.6 mm
Width	53.4 mm
Weight-	25 g

FIRE EXTINGUISHER

Model.no	SE-SP-ABC-1
Capacity (Kg)	1
Diameter (mm)	86.5
Height (mm)	340
Empty Weight (Kg)	1.3
Filled Weight (Kg)	2.3
Operating Temperature	-20 °C to +55 °C
Working Pressure At 27 °C	15 bar
Maximum Service Pressure	1.8 MPa
Test Pressure	35 bar
Average Discharge Time (s)	8
Discharge Range (mts)	<2
Fire Rating	1A, 8B

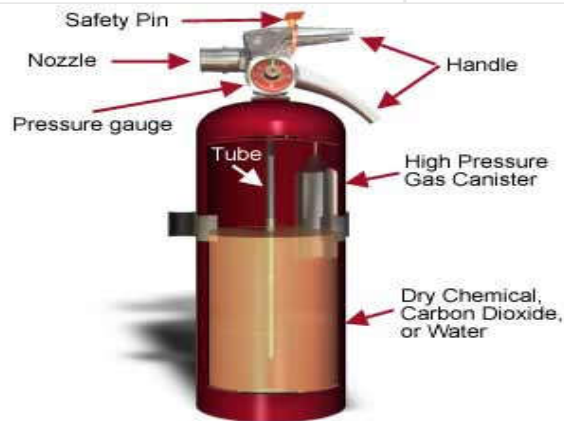

Temperature sensor is used which senses the heat level at specific hot spots. If the temperature exceeds certain limit, a servo motor mechanism is used to activate fire extinguisher.

WORKING:

- Arduino board is the choice of controller board for fire extinguisher activation.
- The temperature sensor is interfaced with the analog input pins.
- The temperature around the motor is being sensed continuously.
- When the temperature exceeds a certain threshold value, PWM pulses are sent to the servomotor.
- The servomotor acts according to the commands of the arduino program and produces necessary torque to pull a rope that will in turn trigger the fire extinguisher to work.

This Automatic Fire Extinguishing system consists of a sensitive temperature sensor, a servo motor and an Arduino Board that has an ATmega 328 microcontroller. As soon the temperature crosses a threshold the temperature sensor senses this and sends signal to the Arduino that in turn sends a command to the servo motor to rotate by an angle of 180°.

WORKING MODEL PICTURE



CONCLUSION

The Automatic Fire Extinguishing system which is implemented in the kart is a step closer to making a fire accident free scenario. This feature can be improvised in the near future to be implemented in all fields where occurrence of fire accidents are more probable, thus saving many lives.

References:

- ✓ <http://www.supremexfireextinguisher.com/fireextinguisher.html>
- ✓ <http://arduino.cc/en/uploads/Main/arduino-uno-schematic.pdf>
- ✓ <http://datasheets.maximintegrated.com/en/ds/DS18B20.pdf>
- ✓ http://www.hobbyking.com/hobbyking/store/_16266_HobbyKing_8482_HK15288A_Analog_BB_MG_Servo_51g_9kg_0_20s.html
- ✓ <http://en.wikipedia.org/>